

**Acue<sup>®</sup>Lighting**

PROFESSIONAL STAGE LIGHTING

**LEGEND**

**— 380 —**



***User Manual***

This manual contains important information.  
Please read before operating fixture.

## TABLE OF CONTENTS

1. GETTING STARTED .....	3
What's In The Box? .....	3
Powering Up! .....	3
Getting A Hold Of Us .....	3
Safety Instructions.....	4
2. MEET THE LEGEND 380.....	5
Main Features.....	5
Control .....	5
DMX Channel Chart (16ch) .....	5
Legend 380 Pin-Up Picture.....	9
The Rear Connections .....	10
3. SETUP.....	10
Fuse Replacement .....	10
Connecting Multiple Fixtures .....	10
Data/DMX Cabling .....	11
Cable Connectors .....	11
Take It To The Next Level: Setting Up DMX Control.....	11
Fixture Linking (M/S Mode).....	12
Mounting & Rigging.....	13
4. OPERATING ADJUSTMENTS.....	14
The Control Panel .....	14
Control Panel Menu Structure.....	15
DMX Mode .....	16
Run Mode.....	17
5. APPENDIX.....	17
Keeping Your Legend 380 As Good As New.....	17
Shipping Issues.....	17
Tech Specs .....	18

# 1. GETTING STARTED

## What's In The Box?

- 1 x Legend 380 fixture
- 1 x Power cable
- 1 x DMX signal cable
- 2 x Omega brackets

## Getting It Out Of the Box

Congratulations on purchasing the Legend 380, an ultra-bright and durable, beam moving head fixture. Now that you've got your Legend 380, you should carefully unpack the box/case and check the contents to ensure that all parts are present and in good condition. If anything looks as if it has been damaged in transit, notify the shipper immediately and keep the packing material for inspection. Again, please save the carton and all packing materials.

## Powering Up!

All fixtures must be powered directly off a switched circuit and cannot be run off a rheostat (variable resistor) or dimmer circuit, even if the rheostat or dimmer channel is used solely for a 0% to 100% switch.

Warning! All fixtures must be connected to circuits with proper grounding.

## Getting A Hold Of Us

If something happens to go wrong, please feel free to contact us. Even though all fixtures go through a tedious testing process, products can still be damaged during shipping.

**Disclaimer:** The information and specifications contained in this document are subject to change without notice. We assume no responsibility or liability for any errors or omissions that may appear in this user manual.

We reserve the right to update the existing document or to create a new document to correct any errors or omissions at any time.

## Safety Instructions



Please read the instructions carefully. They include important information about the installation, usage and maintenance of this product.

- Please keep this User manual for future use. Make sure all users of this product have read the user manual thoroughly.
- ALWAYS make sure that you are connecting to an outlet with the proper voltage, and that the line voltage you are connecting to is not higher than that stated on the decal or rear panel of the fixture.
- Make sure there are no flammable materials close to the unit while operating.
- The unit must be installed in a location with adequate ventilation, at least 20in (50cm) from any adjacent surfaces. Be sure that none of the ventilation slots are blocked prior to operating.
- ALWAYS disconnect from the power source before servicing.
- ALWAYS secure mounted fixtures with a safety cable. NEVER carry the fixture by its head. Use its carrying handles.
- DO NOT operate at ambient temperatures higher than 104°F (40°C).
- In the event of a serious operating problem, stop using the unit immediately. NEVER try to repair the unit by yourself. Repairs carried out by unskilled individuals can lead to further damage or malfunction. Please contact the nearest authorized service center.
- **NEVER connect the device to a dimmer pack.**
- **Make sure the power cord is never crimped or damaged.**
- **Never disconnect the power cord by pulling or tugging on the cord.**
- **Avoid direct eye exposure to the light source while it is on.**

**Caution!** There are no user serviceable parts inside the unit. Do not open the housing or attempt any repairs yourself.

## 2. MEET THE LEGEND 380

### Main Features

- Channel mode: 16 DMX Channels
- Pan scan: 540°(16bit) w/ Electric correction
- Tilt scan: 270° (16bit) w/ Electric correction
- Color wheel: 14 colors + white, with one rainbow color wheel
- Gobo: 17 gobos + white
- 2x Rotating prisms, effect move, & frost filter
- 0-100% mechanical dimming, mechanical dimming and free dimming available.
- Strobe macro control available.
- Beam angle 0~4°
- Over-heat protection
- Power Input: 100-240V, 50/60Hz
- Max Power Draw: 400W
- IP level :IP20
- 3/5 Pin DMX in/out
- Product Size: 350×280×553mm
- Packing Size: 560×440×380mm,packing in carton (custom case sizes differ)
- Net weight: 16.53KG (custom case weights differ)

### Control

- Protocol: DMX-512
- DMX channels: 16ch
- 3-pin XLR DMX input/output
- Easy-to-use 5-button control panel with LCD display
- Operating modes: DMX512, master/slave, auto, sound

### DMX Channel Chart (16ch)

CH	Channel	DMX value	Description
1	Pan	0-255	0-540°

2	Tilt	0-255	0-270°
3	Pan 16bit	0-255	0-2°
4	Tilt 16bit	0-255	0-1°
5	Pan/Tilt Speed Pan/Tilt Time	0-255	Fast → Slow
6	Frost/rainbow	0-127	Insert 7 colorful
		128-255	Insert frost
7	Strobe	0-3	close
		4-103	Strobe from slow to fast
		104-107	open
		108-207	Strobe from slow to fast
		208-212	open
		213-251	Free strobe
		252-255	open
8	Dimmer	0-255	0-100% dimmer
9	Color wheel	0-4	White
		5-9	White + Color 1
		10-14	Color 1
		15-19	Color 1+ Color 2
		20-24	Color 2
		25-29	Color 2+ Color 3
		30-34	Color 3
		35-39	Color 3+ Color 4
		40-44	Color 4
		45-49	Color 4+ Color 5
		50-54	Color 5
		55-59	Color 5+ Color 6
		60-64	Color 6
		65-69	Color 6+ Color 7
		70-74	Color 7
		75-79	Color 7+ Color 8
		80-84	Color 8
		85-89	Color 8+ Color 9
		90-94	Color 9
		95-99	Color 9+ Color 10
100-104	Color 10		
105-109	Color 10+ Color 11		
110-114	Color 11		
115-119	Color 11+ Color 12		
120-124	Color 12		
125-129	Color 12+ Color 13		

		130-134	Color 13
		135-139	Color 13+ Color 14
		140-144	Color 14
		145-149	Color 14+ White
		150-200	Rotate forward (fast to slow)
		201-255	Rotate forward (slow to fast)
10	Color wheel	0-4	White
		5-9	Gobo 1
		10-14	Gobo 2
		15-19	Gobo 3
		20-24	Gobo 4
		25-29	Gobo 5
		30-34	Gobo 6
		35-39	Gobo 7
		40-44	Gobo 8
		45-49	Gobo 9
		50-54	Gobo 10
		55-59	Gobo 11
		60-64	Gobo 12
		65-69	Gobo 13
		70-74	Gobo 14
		75-79	Gobo 15
		80-84	Gobo 16
		85-89	Gobo 17
		90-128	Gobos from fast to slow clockwise
		129-170	Gobos counter-clockwise from slow to fast
		171-175	Gobo 1 shake ,from slow to fast
		176-180	Gobo 2 shake ,from slow to fast
		181-185	Gobo 3 shake ,from slow to fast
		186-190	Gobo 4 shake ,from slow to fast
		191-195	Gobo 5 shake ,from slow to fast
		196-200	Gobo 6 shake ,from slow to fast
		201-205	Gobo 7 shake ,from slow to fast
		206-210	Gobo 8 shake ,from slow to fast
		211-215	Gobo 9 shake ,from slow to fast
		216-220	Gobo 10 shake ,from slow to fast
		221-225	Gobo 11 shake ,from slow to fast
		226-230	Gobo 12 shake ,from slow to fast
		231-235	Gobo 13 shake ,from slow to fast
		236-240	Gobo 14 shake ,from slow to fast
		241-245	Gobo 15 shake ,from slow to fast
		246-250	Gobo 16 shake ,from slow to fast

		251-255	Gobo 17 shake, from slow to fast
11	Prism 1	0-127	Prism off
		128-255	Insert prism 1
12	Prism 1 rotation	0-127	0-400°
		128-187	Rotation Clockwise (fast to slow)
		188-195	Stop
		196-255	Rotation Clockwise (slow to fast)
13	Prism 2	0-127	Prism off
		128-255	Insert prism 2
14	Prism 2 rotation	0-127	0-400°
		128-187	From fast to slow clockwise
		188-195	Stop
		196-255	Counter-clockwise from slow to fast
15	Focus	0-255	From far to near
16	Reset	100-105	Turn off the light source. Hold 5 seconds
		200-205	Turn on the light source. Hold 5 seconds
		210-215	Reset XY. Hold 3 seconds
		220-235	Reset effect motor. Hold 5 seconds
		240-255	Reset All. Hold 5 seconds

# Acue<sup>®</sup>Lighting

PROFESSIONAL STAGE LIGHTING

## Legend 380 Pin-Up Picture



## The Rear Connections



## 3. SETUP



Before replacing a fuse, disconnect the power cord.  
ALWAYS replace with the same type and rating of fuse.

### Fuse Replacement

The Legend 380 utilizes a high-output automatic switching power supply with an internal fuse. Under normal operating conditions, the fuse should not require replacement. The fuse is field replaceable, however it is an advanced procedure suited for qualified technicians. Should the fuse require replacement, please contact your local service center.

### Connecting Multiple Fixtures

You will need a serial data link (DMX Cable) to control the fixtures in DMX Mode. To run built-in shows on two or more fixtures set to sync in master/slave operating mode. The combined number of channels available in each universe will determine how many fixtures you can link to each other via DMX cable.

Fixtures on a serial data link must be daisy chained in one single line or by using a DMX data distribution panel. Connecting more than 8 fixtures on one

serial data link without the use of a DMX optically - isolated splitter may result in deterioration of the digital DMX signal. The maximum recommended cable-run distance is 500 meters (1640 ft). The maximum recommended number of fixtures on a single serial data link is 8 fixtures.

## Data/DMX Cabling

To link fixtures together you will need DMX data cables. You should use data-grade cables that can carry a high quality signal and are less prone to electromagnetic interference.

**In any event, the cable should have the following characteristics:**

- 2-conductor twisted pair plus a shield
- Maximum capacitance between conductors – 30 pF/ft.
- Maximum capacitance between conductor & shield – 55 pF/ft.
- Maximum resistance of 20 ohms / 1000 ft.
- Nominal impedance 100 – 140 ohms

## Cable Connectors

Cables must have a male XLR connector on one end and a female XLR connector on the other end.

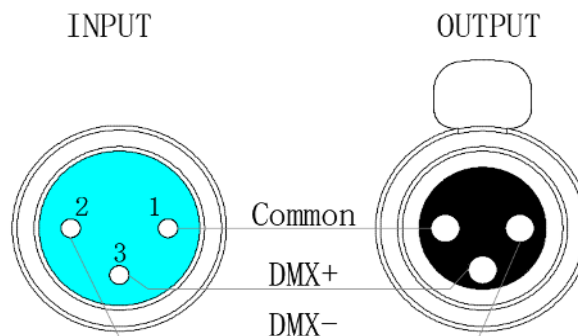

**CAUTION:** Do not allow contact between the common and the fixture's chassis ground. Grounding the common can cause a ground loop, and your fixture may perform erratically. Test cables with an ohm meter to verify correct polarity and to make sure the pins are not grounded or shorted to the shield or each other.

## Take It To The Next Level: Setting Up DMX Control

**Step 1:** Connect the male connector of the DMX cable to the female connector (output) on the controller.

**Step 2:** Connect the female connector of the DMX cable to the first fixture's

male connector (input).

**Note:** It doesn't matter which fixture address is the first one connected. We recommend connecting the fixtures in terms of their proximity to the controller, rather than connecting the lowest fixture number first, and so on.

**Step 3:** Connect other fixtures in the chain from output to input as above. Place a DMX terminator on the output of the final fixture to ensure best communication.

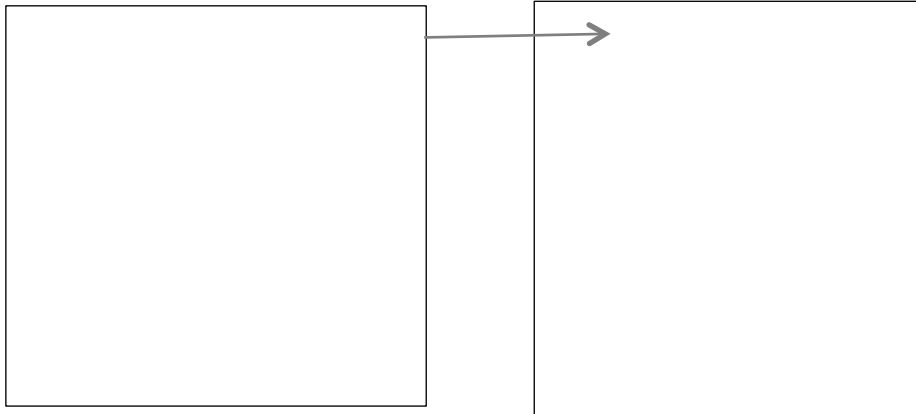

## Fixture Linking (M/S Mode)

1. Connect the male connector side of the DMX cable to the output female connector of the first fixture.
2. Connect the end of the cable coming from the first fixture which will have a female connector to the input connector of the next fixture consisting of a male connector. Then, proceed to connect from the output as stated above to the input of the following fixture and so on.

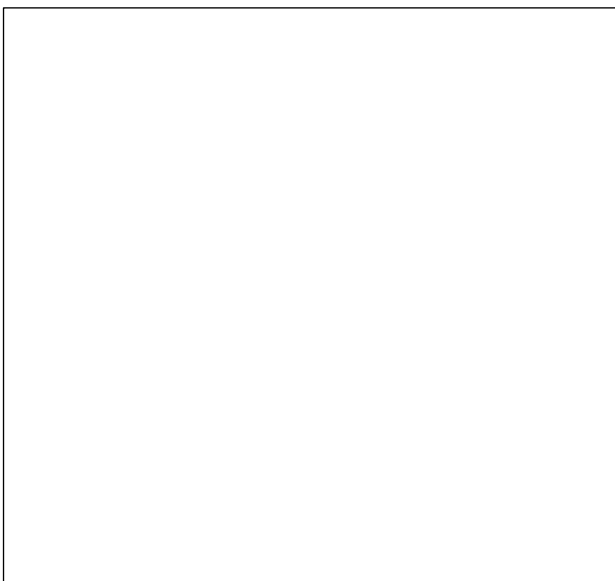

**NOTE:** Often, the setup for Master-Slave and Standalone operation requires that the first fixture in the chain be initialized for this purpose via either setting in the control panel. Second, the fixtures that follow may also require a slave setting.

Check the “**Operating Adjustments**” section in this manual for complete instructions for this type of setup and configuration.

## **Mounting & Rigging**

This fixture may be mounted in any SAFE position provided there is enough room for ventilation and rotation clearance. The fan or vents pathway must never be obstructed. The Legend 380 can be placed horizontally, diagonally or upside down. Pay attention to the installation method when slanted and upside down.

A mounting bracket assembly is provided that secures the bottom of the base, Omega bracket, and the safety cable rigging point together. When mounting to truss, be sure to secure an appropriately rated clamp to the omega bracket.

**IMPORTANT:** Regardless of the rigging option you choose for your fixtures, always be sure to secure your fixture with a safety cable.

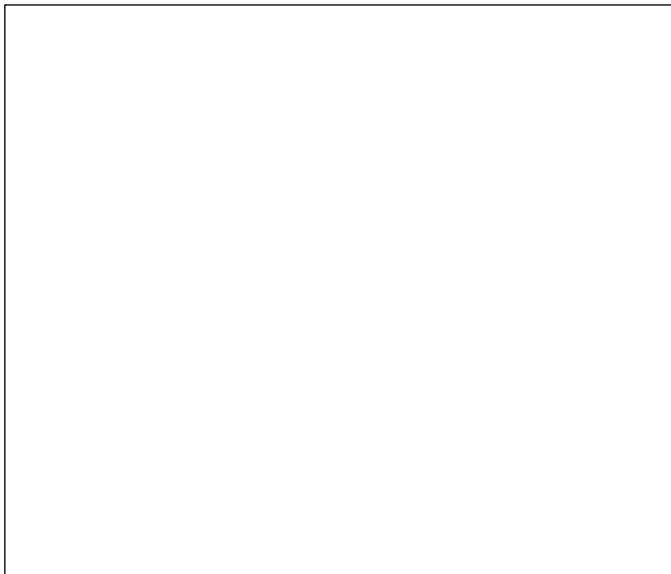

Attach the 2x ¼-turn quick lock Omega brackets to the base, and the clamps to the brackets.

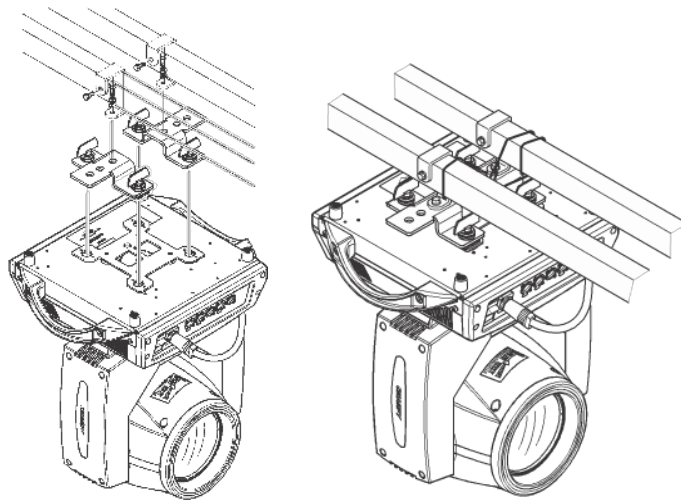

Mount the fixture using a suitable "C" or "O" type clamps. The clamps should be rated to hold at least 10x the fixture's weight to ensure structural stability. Do not mount to surfaces of unknown strength, and ensure properly rated rigging is used when mounting fixtures overhead.

Overhead mounting requires extensive experience, which includes calculating working load limits, knowledge of the installation material being used, and periodic safety inspections. If you lack these qualifications, do not attempt the installation yourself. Improper installation can result in bodily injury.

## 4. OPERATING ADJUSTMENTS

### The Control Panel

All of the features and modes possible with the Legend 380 can be accessed through the control panel on the front of the fixture. There are 4 control buttons next to the LED display, which allow you to navigate through the various control panel menus.

**<MENU>** Is used to navigate to the previous higher-level menu item.

**<UP>** Scrolls through menu items and numbers in ascending order.

**<DOWN>** Scrolls through menu items and numbers in descending order.

**<OK>** Is used to confirm and go to the options.

**<ENTER>** Is used to left and right selection menu.

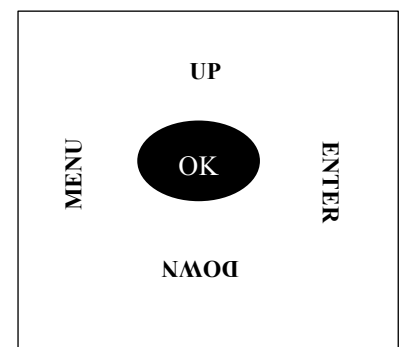

Pressing any button from the home screen will show the selectable menu items from the menu map on page #15. When a menu function is selected, the display will immediately show the first available option for the selected menu function. To select a menu item, press **<MENU>**.

Use the <UP> and <DOWN> buttons to navigate the menu options. Press the <OK> button to select the menu function currently displayed. If you want to select the menu from left to right, press the < ENTER > button.

## Control Panel Menu Structure

DMX	Address	001-512
Mode	DMX Ctrl	
	Auto Run	
	Sound Ctrl	
	Scene Mode	Auto/01/02...10
	M/S Choose	Auto/Master/Slave
	Light Switch	ON/OFF
Return		
DISP	Language	中文 English
	Screen Saver	Mode1/mode2...mode4/OFF
	Screen Rot	Forward
	DMX Indicate	Mode1/mode2/mode3
	Screen Light	001-009
	Return	
SCENE	Scene Select	1-10
	Scene Time	0.0S
	Control Mode	ON/OFF
	01. Pan	000-255
	02. Tilt	000-255
	03. Pan Fine	000-255
	04. Tilt Fine	000-255
	05. PT speed	000-255
	06. Frost	000-255
	07. Strobe	000-255
	08. Dimmer	000-255
	09. Color	000-255
	10. GOBO	000-255
	11. Prism1	000-255
12. Prism1 R	000-255	
13. Prism2	000-255	

	14. Prism2 R	000-255
	15. Focus	000-255
	16. Reset	000-255
	Return	
ADVA	Pan Invert	ON/OFF
	Tilt Invert	ON/OFF
	P/T Rectify	ON/OFF
	Pan Offset	000-150
	Tilt Offset	000-048
	Data Hold	ON/OFF
	Scene Time	001-255
	Lamp When	RSTDONE/Power ON manual1
	Reset	
	Factory Setting	
	Return	
STAT	Stepper Info	
	Error logging	
	Fixture status	
	Version C7.1.0	
	Light Time	
	Total Time	
	Serial Number	
Exit Menu		

## DMX Mode

Allows the unit to be controlled by any universal DMX controller.

### Starting DMX Address

- 1.) Navigate the main menu until you reach DMX, and press the **<OK>** button.
- 2.) Then highlight Address, and press **<OK>**.
- 3.) Use the **<UP/DOWN>** buttons to select a starting DMX address ranging from 001-512, and press the **<OK>** button to confirm.

### DMX Channel Mode

- 1.) Navigate the main menu until you reach DMX, and press the **<OK>** button.
- 2.) Then highlight Channel Mode, and press **<OK>**.
- 3.) Use the **<UP/DOWN>** buttons to select **Channel 01~20**, and press the **<E>** button to confirm.

## Run Mode

### Run Mode

- 1.) Navigate the main menu until you reach Run, and press the **<OK>** button.
- 2.) Use the **<UP/DOWN>** buttons to highlight **Auto** , **Sound** ,**Slave**, and press the **<OK>** button.
- 3.) To stop an **Auto** or **Sound** program, use the **<UP/DOWN>** buttons to Highlight **Slave**, and press **<OK>**.

## 5. APPENDIX

### Keeping Your Legend 380 As Good As New

The fixture you have purchased is a rugged, tough piece of pro lighting equipment, and as long as you take care of it, it will take care of you. That said, you would need to take care of it if you want it to operate as designed. You should keep the fixture clean, especially if you are using it in an environment with a lot of dust, fog, haze, or moisture.

Cleaning the optics routinely with a suitable glass cleaner will greatly improve the quality of light output. Keeping the fans free of dust and debris will keep the fixture running cool and prevent damage from overheating.

In transit, keep the fixtures in cases. Keeping the fixtures in cases during transport will avoid any damage. The case also has ample space for accessories to be transported with each fixture.

### Shipping Issues

**Damages incurred during shipping are the responsibility of the shipper, and must be reported to the carrier immediately upon receipt of the items. Claims must be made within seven (7) days of receipt.**



PROFESSIONAL STAGE LIGHTING

## Tech Specs

<b>Power</b>	
Operating Voltage	100-240V 50/60Hz
Power Consumption	400w
<b>Light Source</b>	
Osram Sirius HRI	371W lamp
<b>Optical</b>	
Beam Angle	0~4°
<b>Main Feature</b>	
Color Wheel	14 color +white
Gobos Wheel	17 gobos + white
Frost/Rainbow effect	0-100% linear frost + Rainbow effect
Focus	0-100% Motorized focus
Prism	8 prism, 3 layer prism
<b>Movement Range</b>	
Pan	540° 16 bit
Tilt	270° 16 bit
<b>Thermal</b>	
Maximum ambient temp	40° C (104°F)
Maximum surface temp	90° C (194°F)
Minimum operating temp	20° C (68°F)
<b>Control</b>	
Protocol	DMX-512
DMX Channels	16CH
Input/output	3-pin XLR male/female
Other Operating Modes	DMX 512, Auto, Master-slave, Sound
<b>Warranty</b>	1-year limited warranty does not cover malfunctions with lamp or caused by damage to lamp or misuse. Lamps are not covered under warranty.

## 6 AFTER SALES SERVICE

1. Our company offers technical consultation to all customers.
2. If the fixture is damaged and needs repair, please fill in the related fields and return the form to your nearest service center with the fixture for repair.



### Warranty Card

Name	Model	Production	Purchase
------	-------	------------	----------

End User
Company Name:
Add:

Purchase Location:	
Salesperson:	Address:
Tel:	



**Description:** This form must be filled out truthfully & all information must be provided, or else the warranty will not work (warranty period and terms, see the following)

**Warranty period:** One year from date of purchase. Purchase receipt required for purchase verification.

**Warranty terms:** All warranty work orders must be accompanied by original purchase receipt showing date of purchase and location where the purchase was made. Failing to provide proof of purchase will result in work done OUT OF WARRANTY. All out of warranty work performed will incur all costs to the user as a paid service.

**\*The following will be the implementation of paid service:**

- (1) Without the effective warranty card
- (2) There are blank or altered fields or no point-of-sale name
- (3) Damage caused by misuse
- (4) Damage caused by improper transportation or unloading
- (5) Damage caused by not operating within the terms of this manual
- (6) Damage caused by unauthorized repair
- (7) Damage caused by unauthorized control methods

**Note:**

All content in this manual is subject to change without prior written notice.

For more information about this product as well as other products please visit [www.AcueExpress.com](http://www.AcueExpress.com)

Or contact us directly:

Email: [Info@AcueLighting.com](mailto:Info@AcueLighting.com) Phone: (818) 646-7526/ (818) 672-6822